

 Ø 2,5
 Ø 4,2 (M5)

GS B

 Papiersablonen können sich durch Luftfeuchtigkeit verändern. Verbindlich sind daher nur die Maßangaben. Paper templates might distort due to air moisture. Only the indicated measurements are therefore obligatory. Les gabarits en papier peuvent avoir des dimensions modifiées par l'humidité de l'air. Seules les côtes mentionnées doivent être respectées.

- Bohrungen für Montageplatte
Drillings for mounting plate
Alésage pour platine de montage
- Bohrungen für Direktmontage
Drillings for direct mounting
Alésage pour montage direct

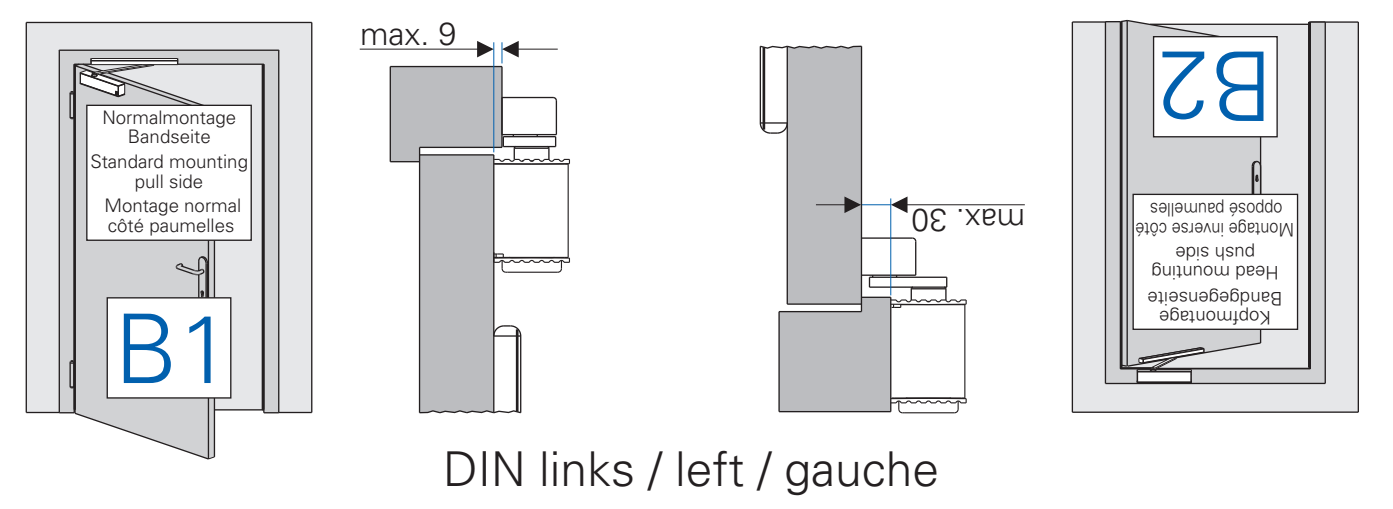
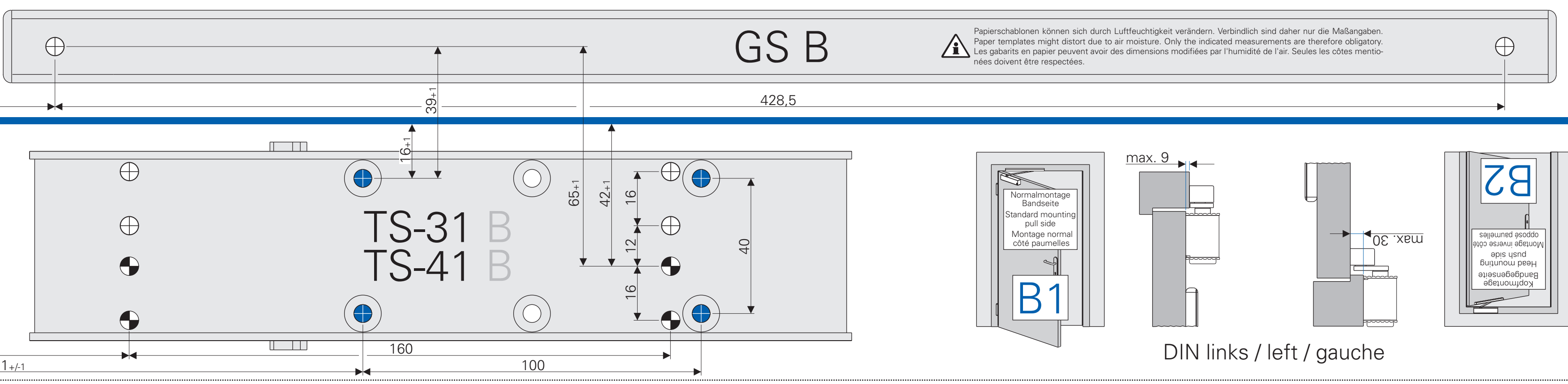

TS-31 EN 1-3 TS-41 EN 1-4

CE	ECO Schulte GmbH & Co. KG Islerlohner Landstraße 89 D-58706 Menden	10
	0432 - CPD - 0031	EN 1154:1996+A1:2002

TS-31 EN 1-3	Türschließergröße Door closer size Force de ferme porte	Max. Türbreite Max. door width Largeur de porte max.	Umdrehungen Rotations Rotations
■1	750 mm	-11	
■2	850 mm	-6	
■3	950 mm	0	

TS-41 EN 1-4	Türschließergröße Door closer size Force de ferme porte	Max. Türbreite Max. door width Largeur de porte max.	Umdrehungen Rotations Rotations
■1	750 mm	-7	
■2	850 mm	-4	
■3	950 mm	0	
■4	1100 mm	+5	

 Für die Montage dürfen ausschließlich Originalteile des Herstellers verwendet werden. Die Montagearbeiten müssen gemäß Anleitung von einer qualifizierten Person durchgeführt werden. Bei Nichtbeachtung entfällt jeglicher Garantieanspruch. Diese Anleitung ist vom Monteur nach der Montage an den Betreiber weiterzugeben!
 Only original parts have to be used. The assembly has to be made by a qualified person according to the mounting instruction. In case of non-respect the guarantee is invalid. This instruction is to be handed over to the operator by the fitter after assembly!
 Impérativement utiliser la notice de montage fournie par le fabricant. La mise en œuvre et le montage doivent être exécutés par du personnel qualifié. Le non respect de ces règles annule catégoriquement tout droit de garantie. Cette instruction est à remettre par le poseur à l'exploitant après montage.

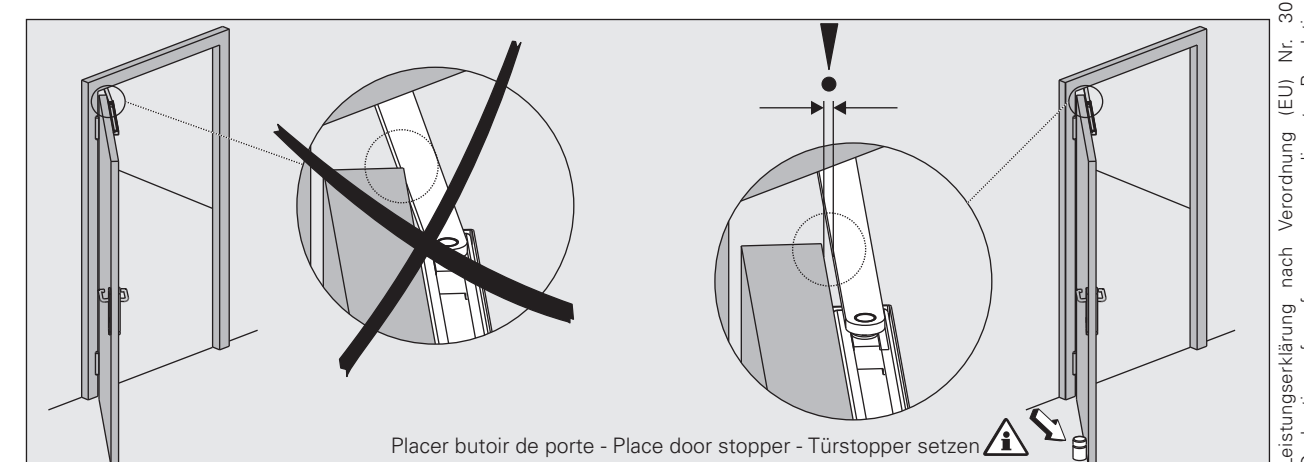
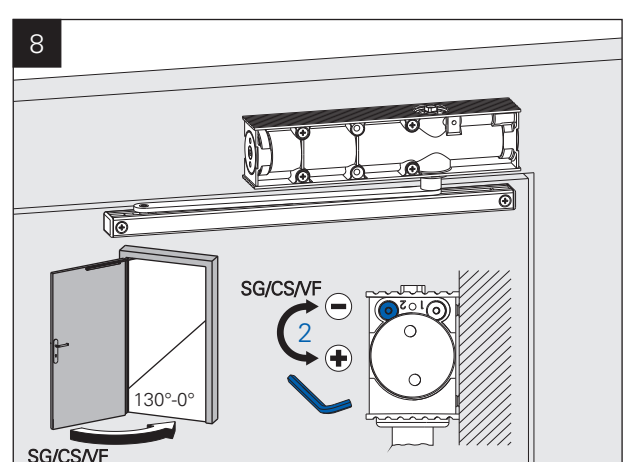
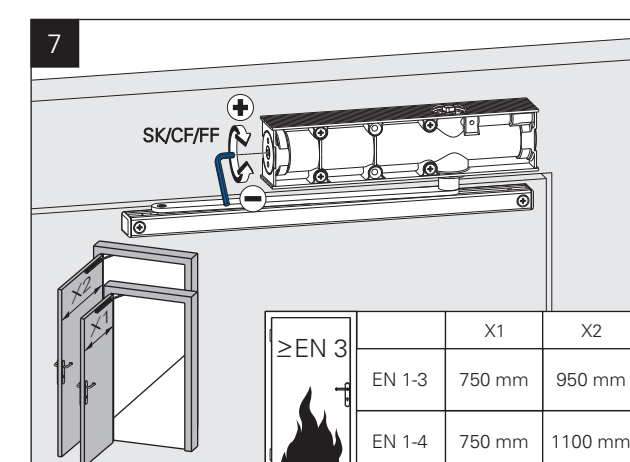
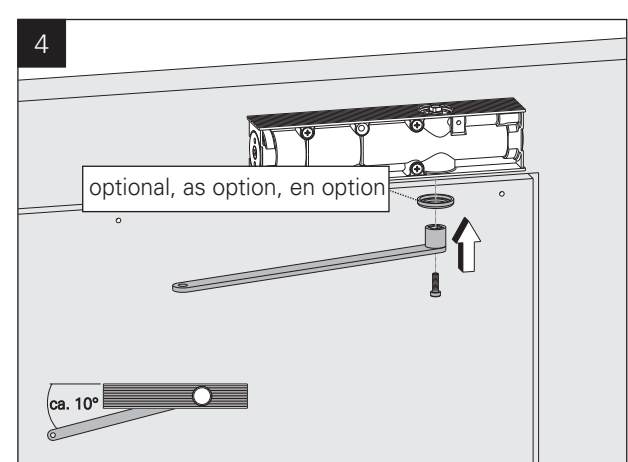
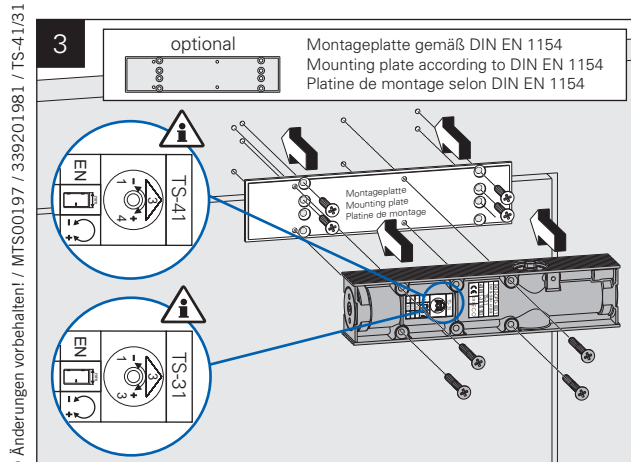
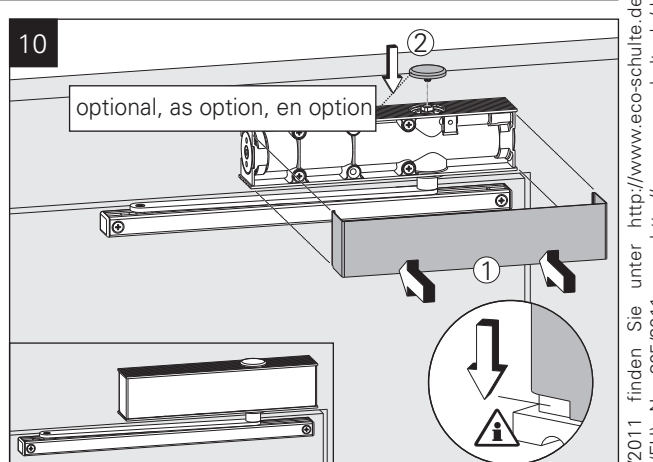
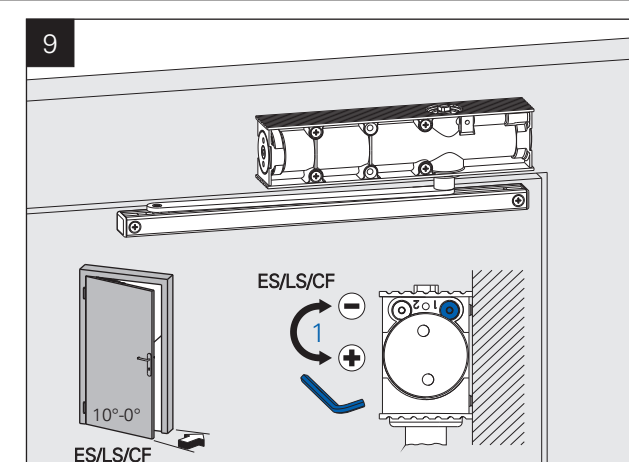
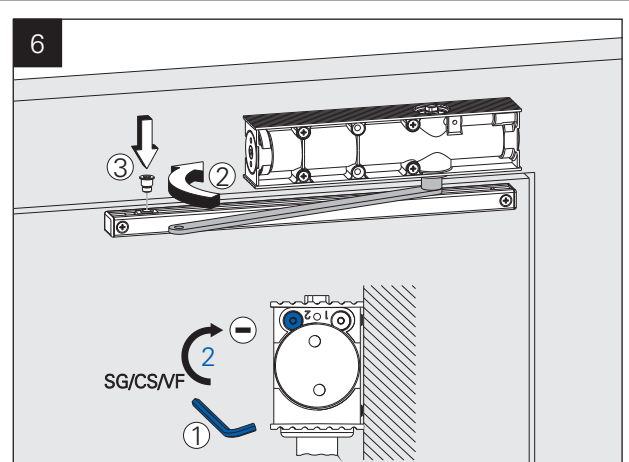
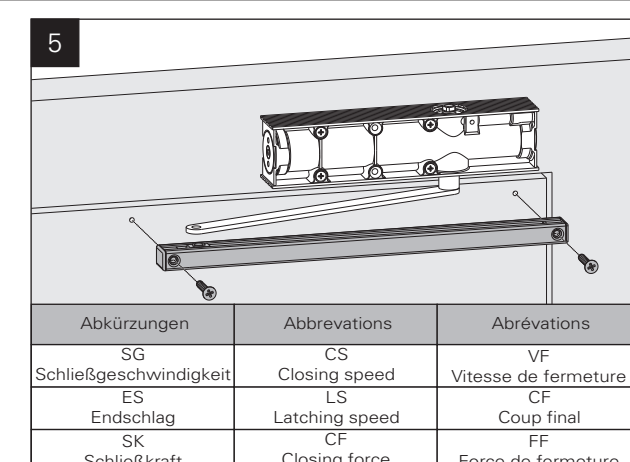
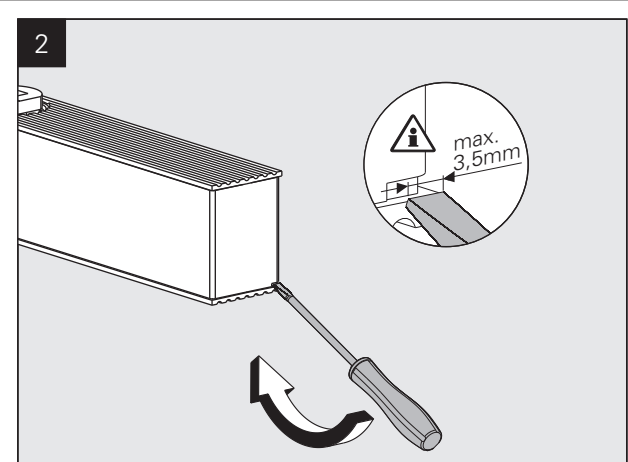
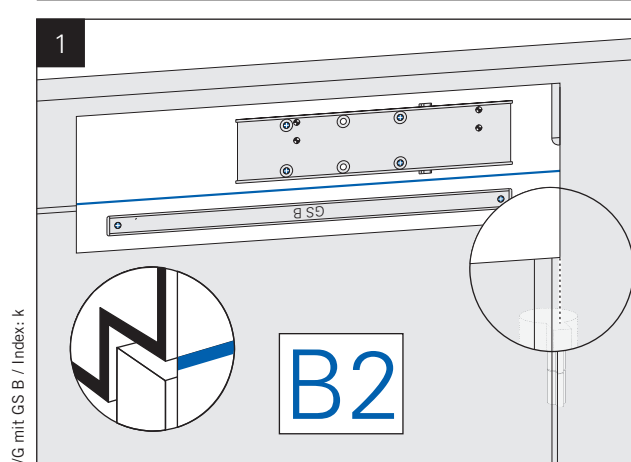
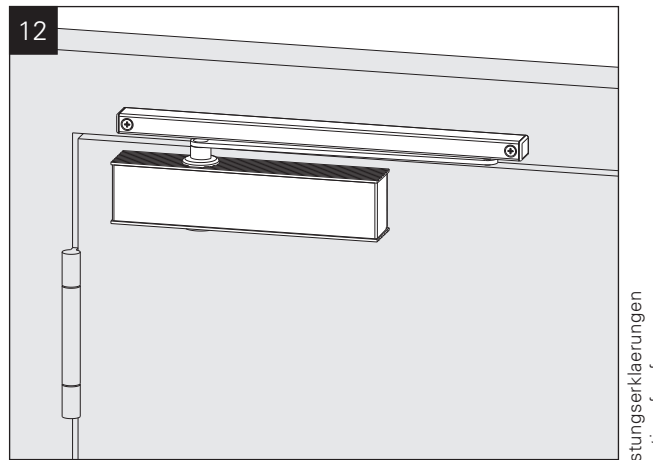
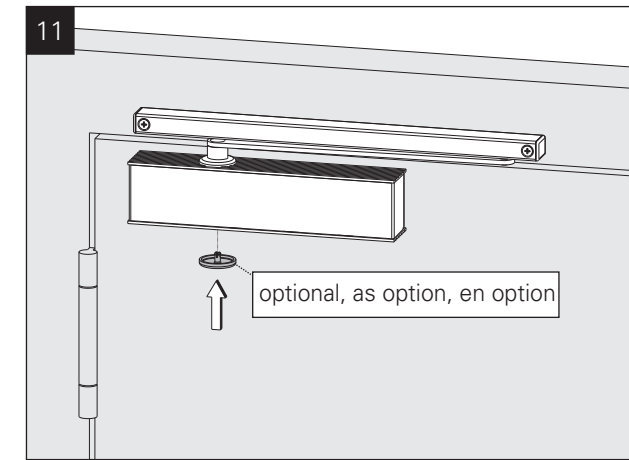
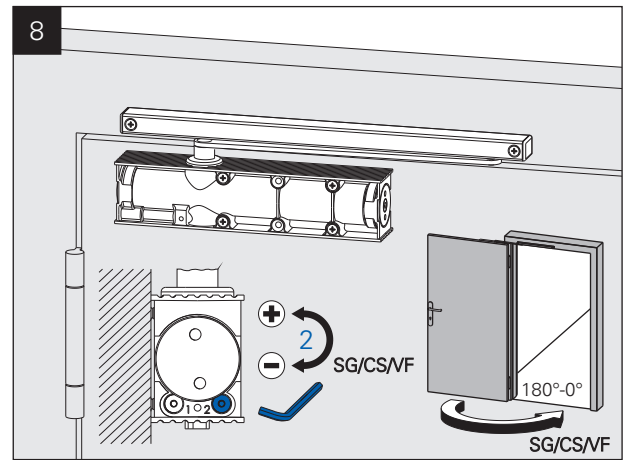
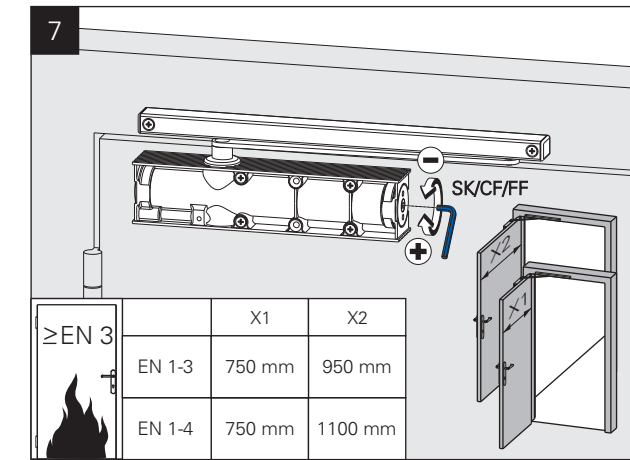
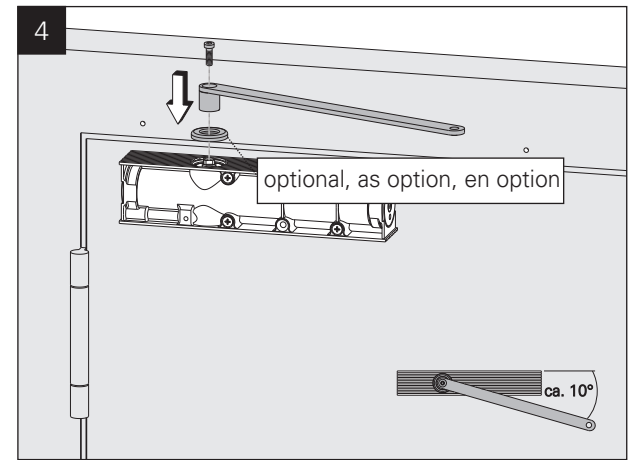
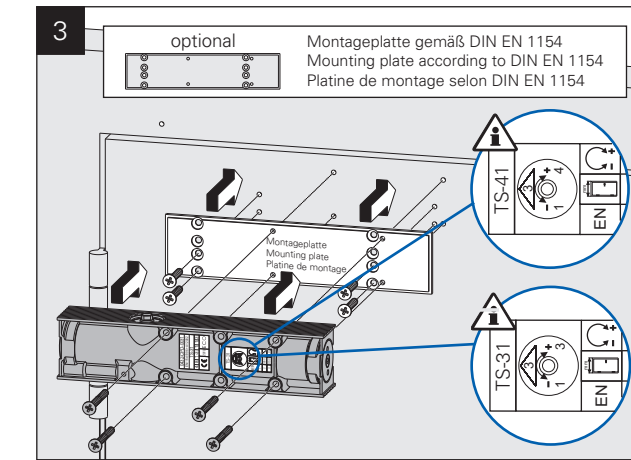
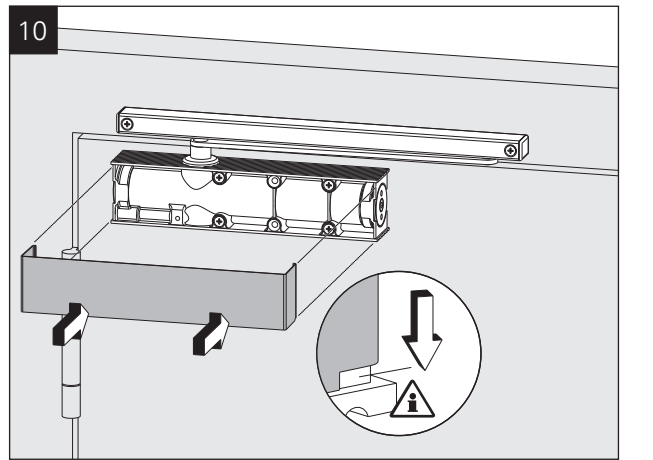
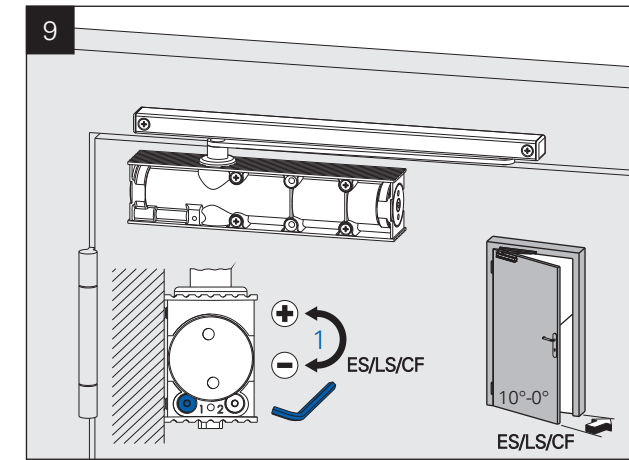
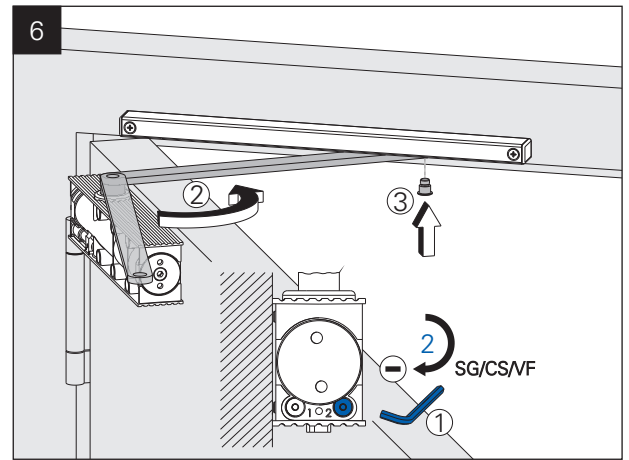
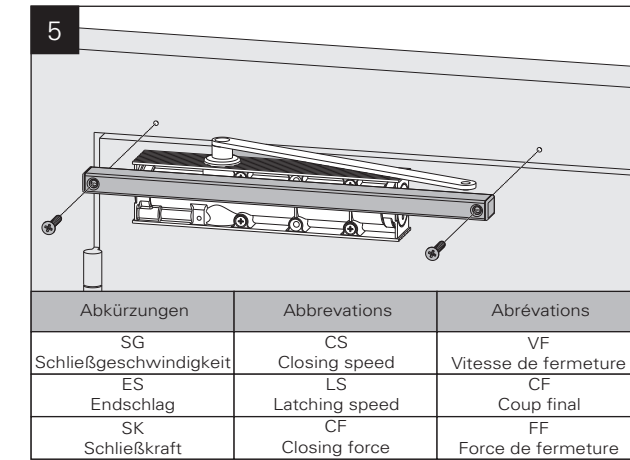
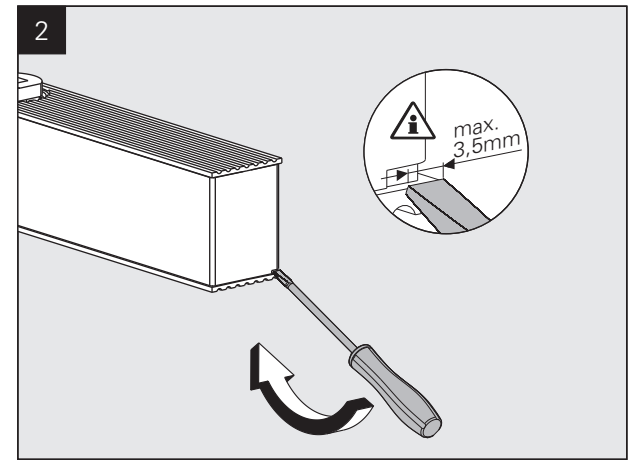
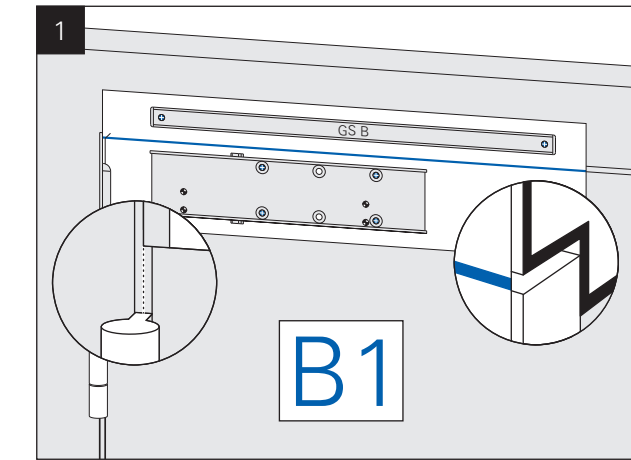

© Änderungen vorbehalten! / MITS00197 / 339201981 / TS-41/31 B/G mit GS B / Index: k

Leistungserklärung nach Verordnung (EU) Nr. 305/2011 finden Sie unter <http://www.eco-schulte.de/leistungserklarungen>
 Declaration of performance according to Regulation (EU) No. 305/2011 see <http://www.eco-schulte.de/declarationofperformance>
 Déclaration des performances conformément au règlement (UE) N° 305/2011 voir <http://www.eco-schulte.de/declarationdesperformances>

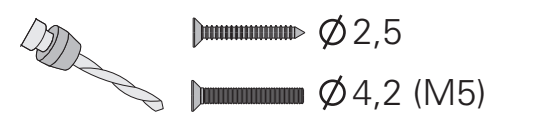
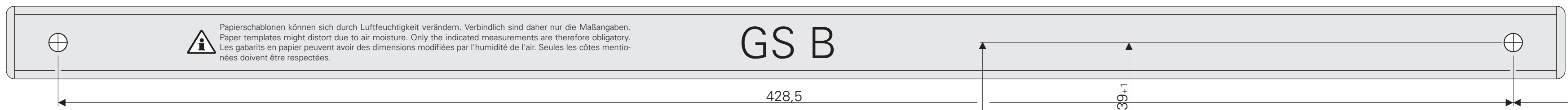

Papiersablonen können sich durch Luftfeuchtigkeit verändern. Verbindlich sind daher nur die Maßangaben.
Paper templates might distort due to air moisture. Only the indicated measurements are therefore obligatory.
Les gabarits en papier peuvent avoir des dimensions modifiées par l'humidité de l'air. Seules les côtes mentionnées doivent être respectées.

GS B

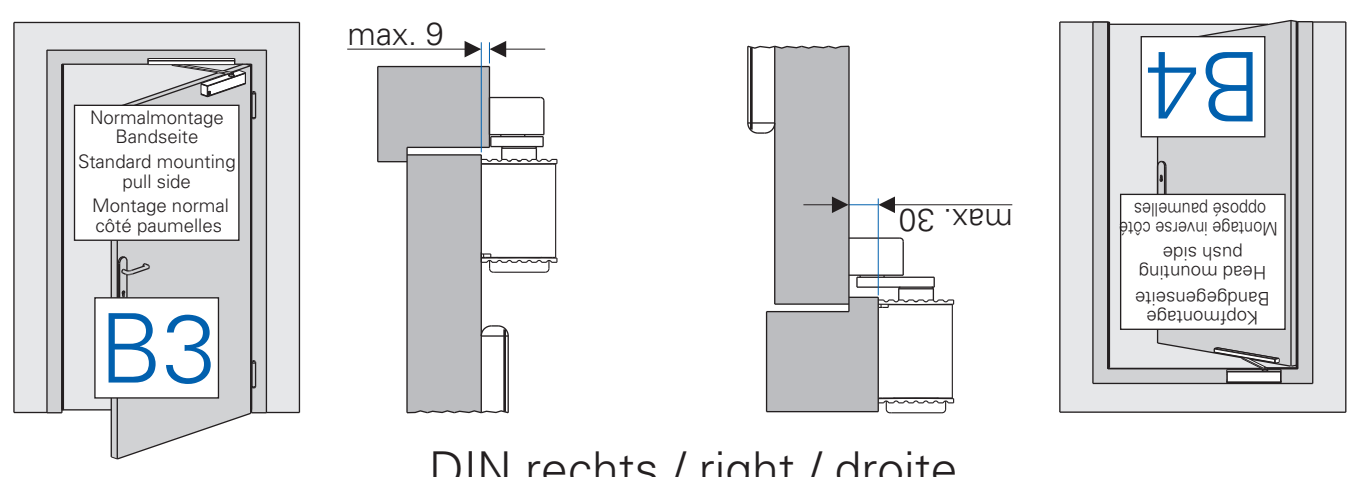

DIN rechts / right / droite

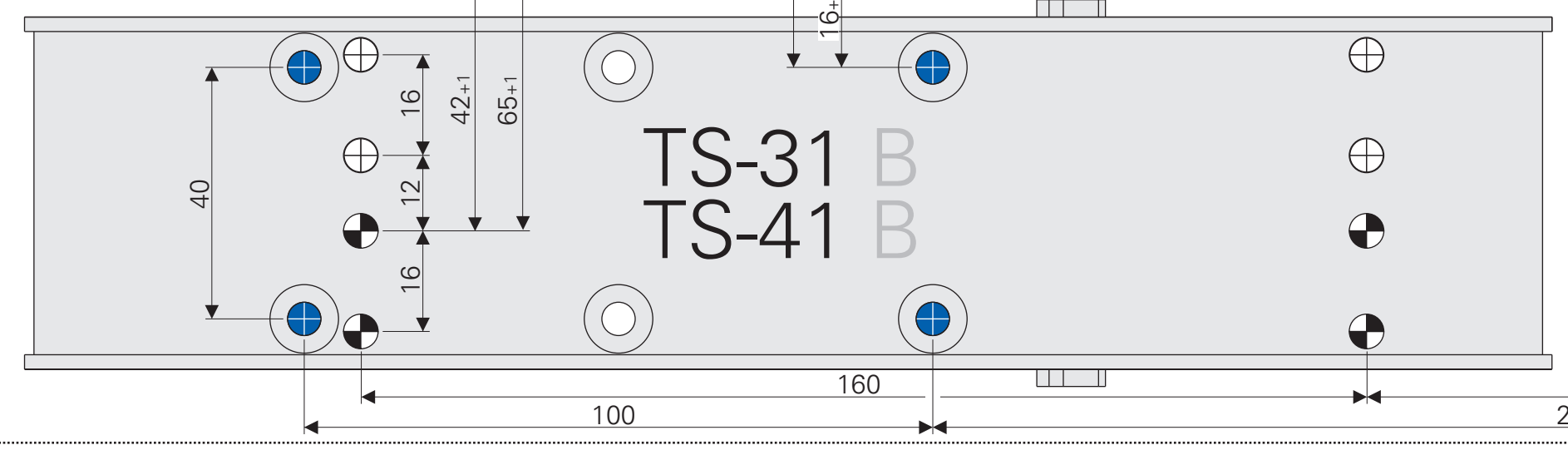

- Bohrungen für Montageplatte
Drillings for mounting plate
Alésage pour platine de montage
- Bohrungen für Direktmontage
Drillings for direct mounting
Alésage pour montage direct

TS-31 EN 1-3 TS-41 EN 1-4

CE	ECO Schulte GmbH & Co. KG Iserlohner Landstraße 89 D-58706 Menden	10
	0432 - CPD - 0031	EN 1154:1996+A1:2002

TS-31 EN 1-3	Türschließergröße Door closer size Force de ferme porte	Max. Türbreite Max. door width Largeur de porte max.	Umdrehungen Rotations Rotations
■1	750 mm	-11	
■2	850 mm	-6	
■3	950 mm	0	

TS-41 EN 1-4	Türschließergröße Door closer size Force de ferme porte	Max. Türbreite Max. door width Largeur de porte max.	Umdrehungen Rotations Rotations
■1	750 mm	-7	
■2	850 mm	-4	
■3	950 mm	0	
■4	1100 mm	+5	

Für die Montage dürfen ausschließlich Originalteile des Herstellers verwendet werden. Die Montagearbeiten müssen gemäß Anleitung von einer qualifizierten Person durchgeführt werden. Bei Nichtbeachtung entfällt jeglicher Garantieanspruch. Diese Anleitung ist vom Monteur nach der Montage an den Betreiber weiterzugeben!
Only original parts have to be used. The assembly has to be made by a qualified person according to the mounting instruction. In case of non-respect the guarantee is invalid. This instruction is to be handed over to the operator by the fitter after assembly!
Impérativement utiliser la notice de montage fournie par le fabricant. La mise en œuvre et le montage doivent être exécutés par du personnel qualifié. Le non respect de ces règles annule catégoriquement tout droit de garantie. Cette instruction est à remettre par le poseur à l'exploitant après montage.

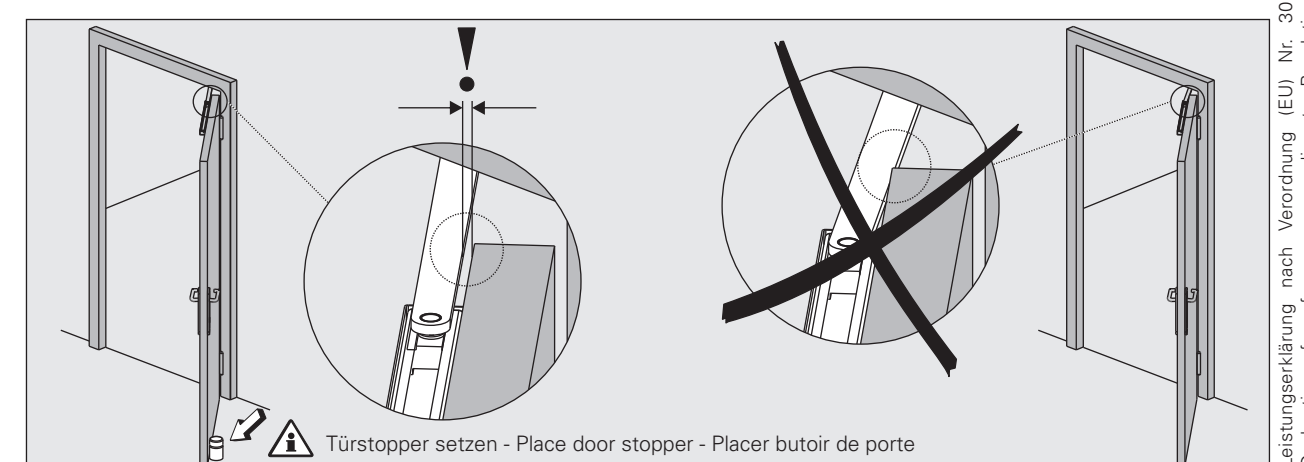
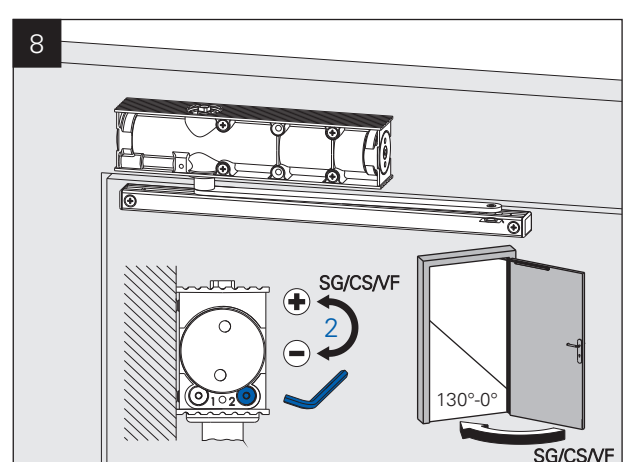
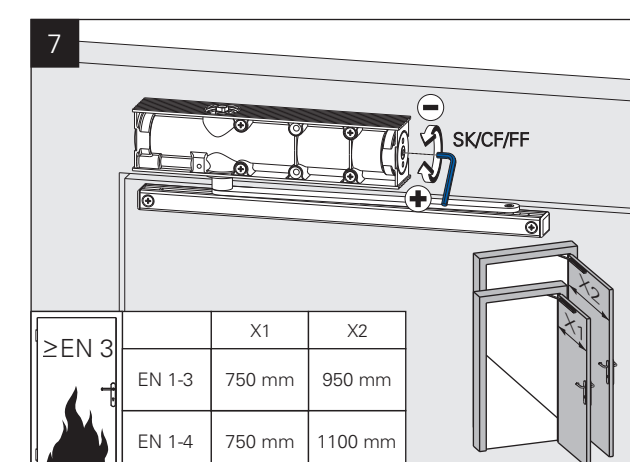
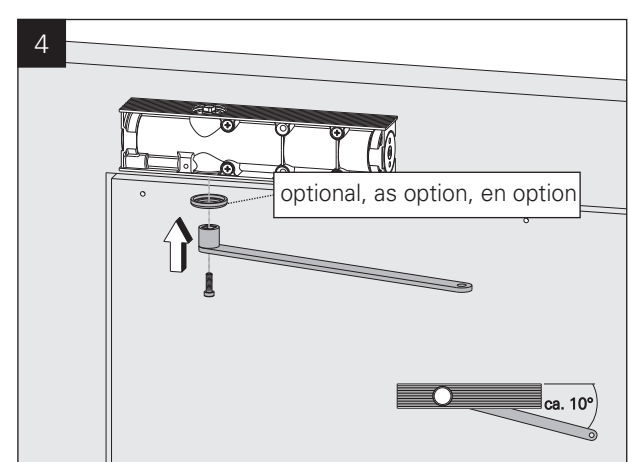
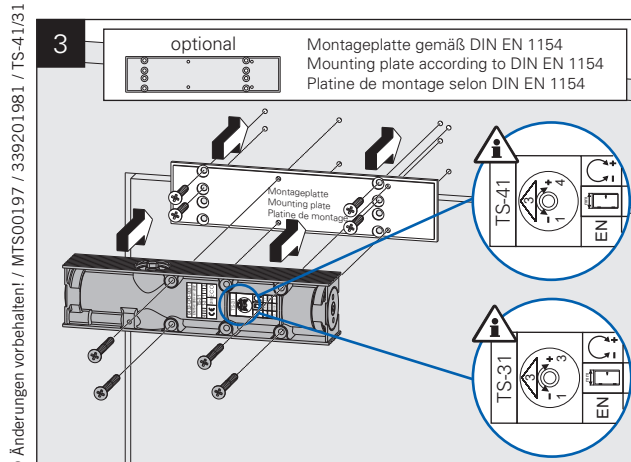
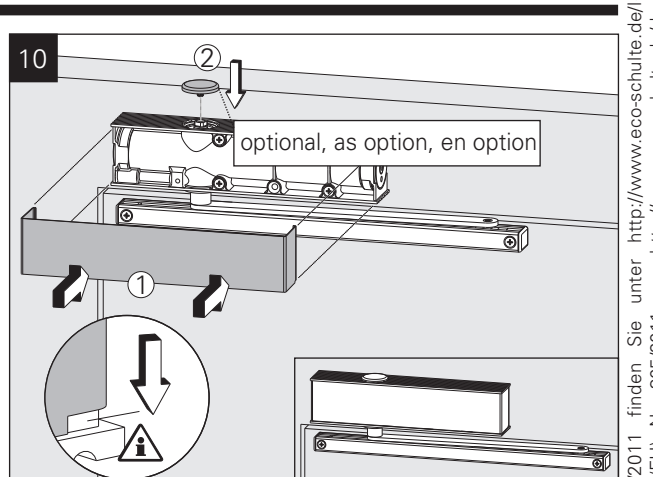
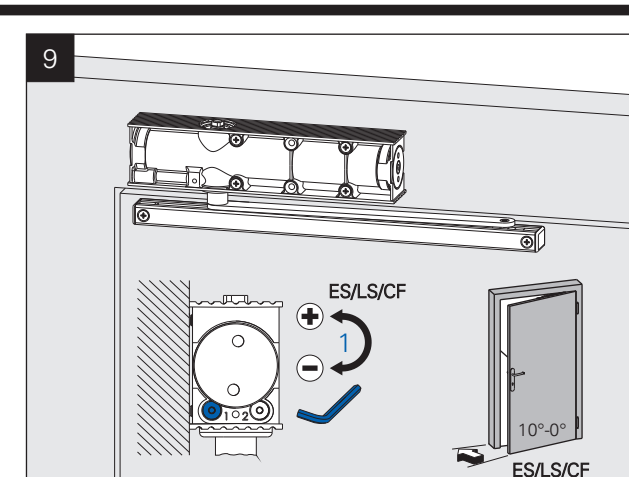
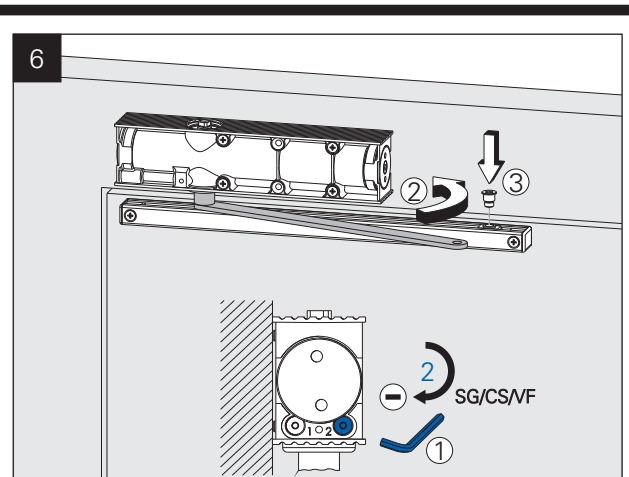
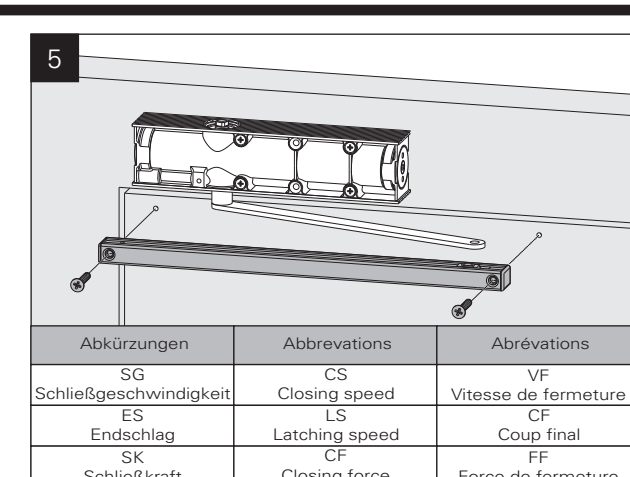
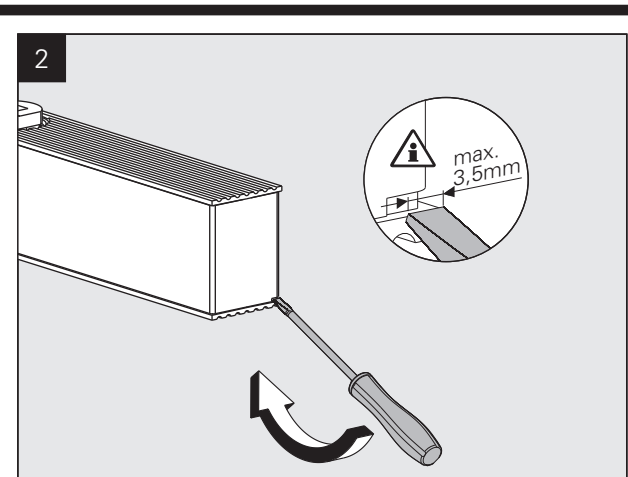
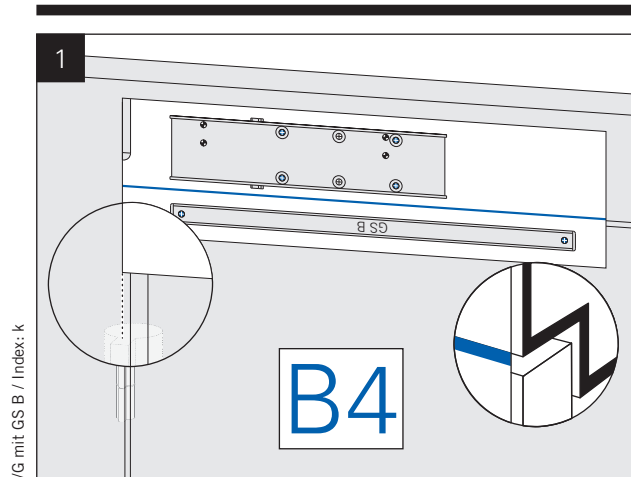
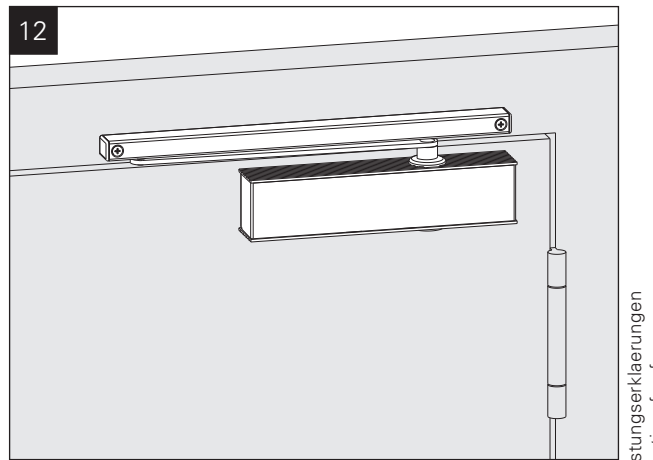
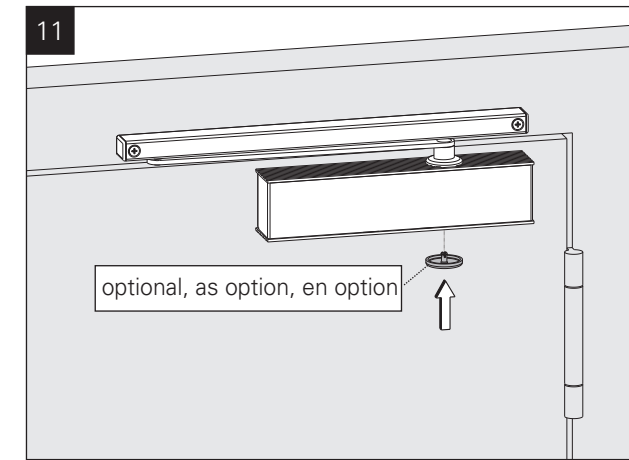
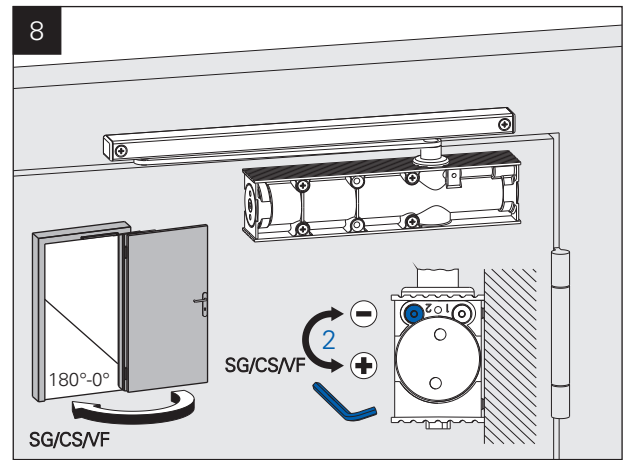
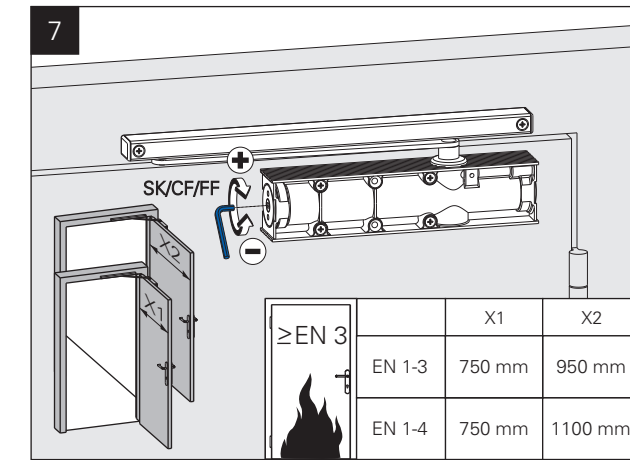
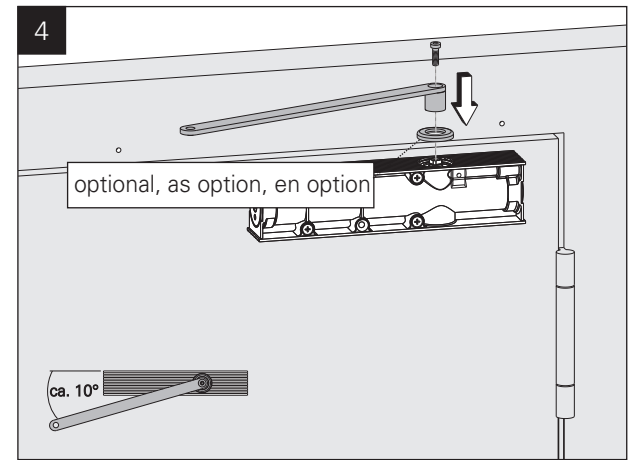
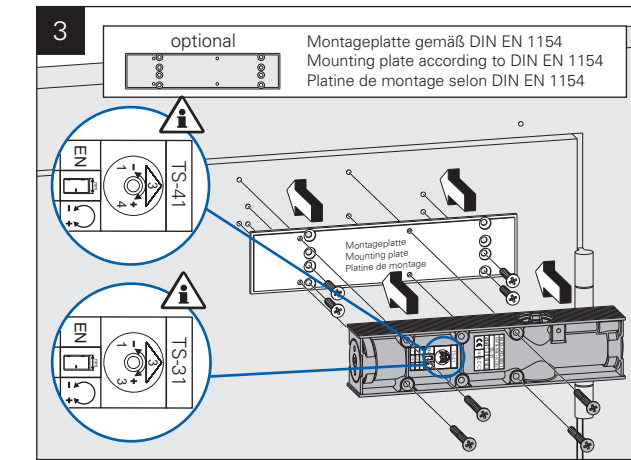
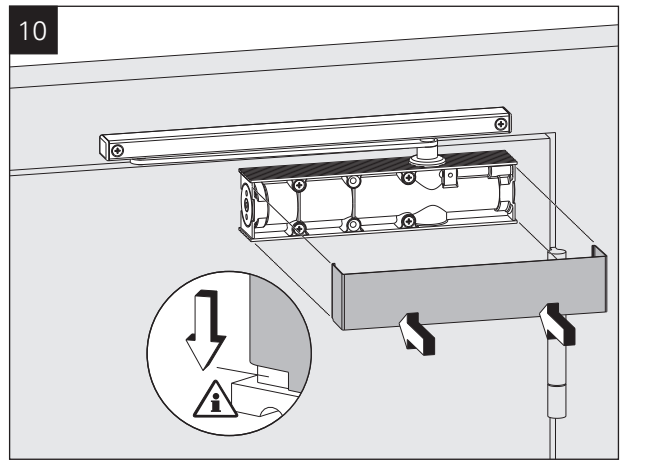
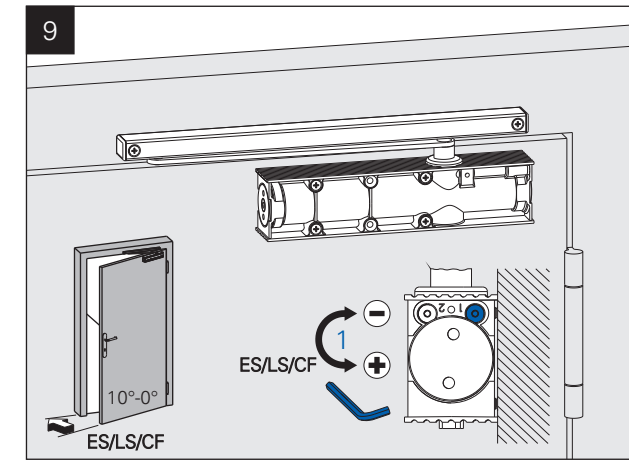
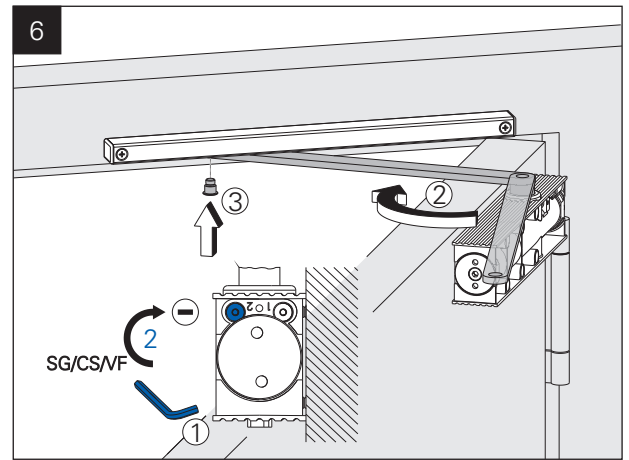
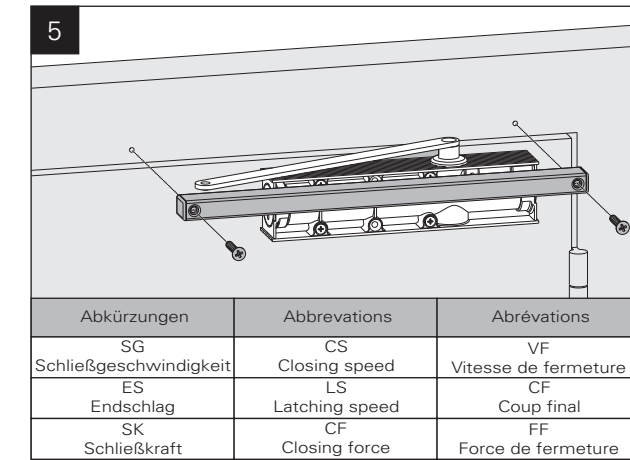
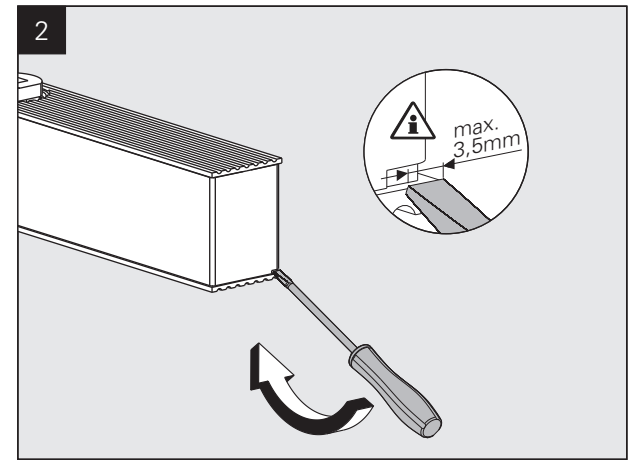
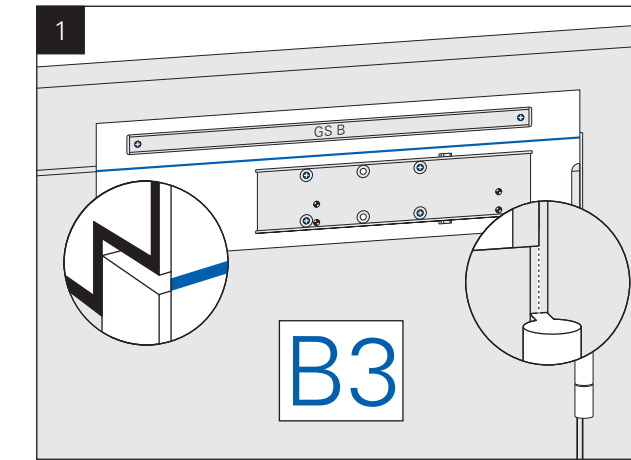

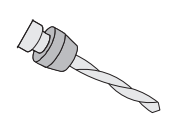
 Ø 2,5
 Ø 4,2 (M5)

GS B

 Papiersablonen können sich durch Luftfeuchtigkeit verändern. Verbindlich sind daher nur die Maßangaben. Paper templates might distort due to air moisture. Only the indicated measurements are therefore obligatory. Les gabarits en papier peuvent avoir des dimensions modifiées par l'humidité de l'air. Seules les côtes mentionnées doivent être respectées.

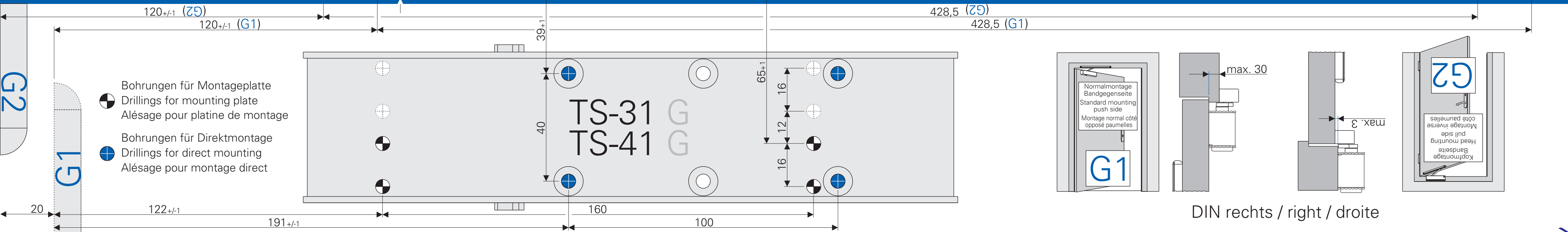

TS-31 EN 1-3 TS-41 EN 1-4

CE	ECO Schulte GmbH & Co. KG Iserlohner Landstraße 89 D-58706 Menden	10
	0432 - CPD - 0031	EN 1154:1996+A1:2002

Türschließergröße Door closer size Force de ferme porte	Max. Türbreite Max. door width Largeur de porte max.	Umdrehungen Rotations Rotations
■1	750 mm	-11
■2	850 mm	-6
■3	950 mm	0

Türschließergröße Door closer size Force de ferme porte	Max. Türbreite Max. door width Largeur de porte max.	Umdrehungen Rotations Rotations
■1	750 mm	-7
■2	850 mm	-4
■3	950 mm	0
■4	1100 mm	+5

 Für die Montage dürfen ausschließlich Originalteile des Herstellers verwendet werden. Die Montagearbeiten müssen gemäß Anleitung von einer qualifizierten Person durchgeführt werden. Bei Nichtbeachtung entfällt jeglicher Garantieanspruch. Diese Anleitung ist vom Monteur nach der Montage an den Betreiber weiterzugeben!
 Only original parts have to be used. The assembly has to be made by a qualified person according to the mounting instruction. In case of non-respect the guarantee is invalid. This instruction is to be handed over to the operator by the fitter after assembly!
 Impérativement utiliser la notice de montage fournie par le fabricant. La mise en œuvre et le montage doivent être exécutés par du personnel qualifié. Le non respect de ces règles annule catégoriquement tout droit de garantie. Cette instruction est à remettre par le poseur à l'exploitant après montage.

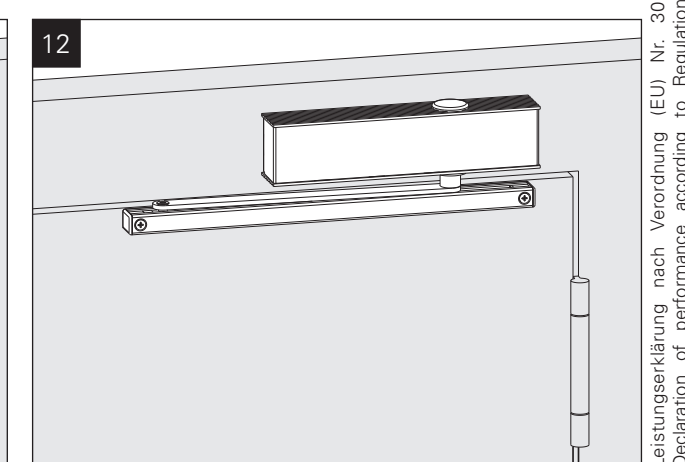
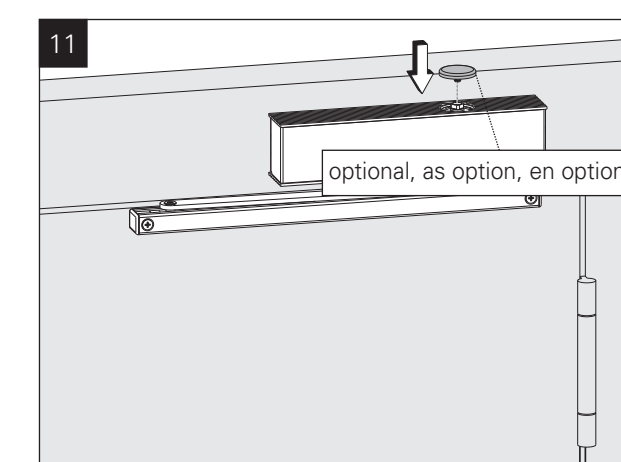
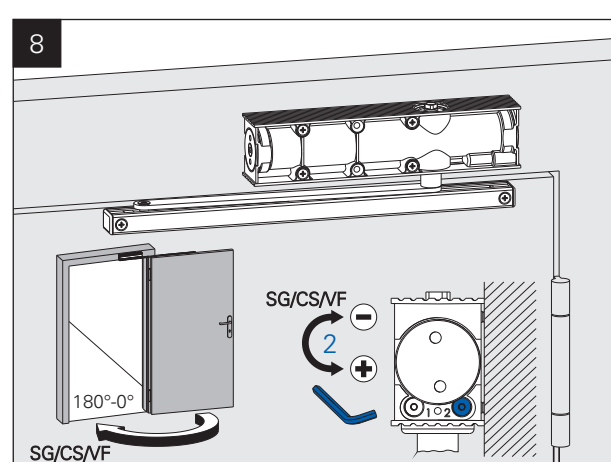
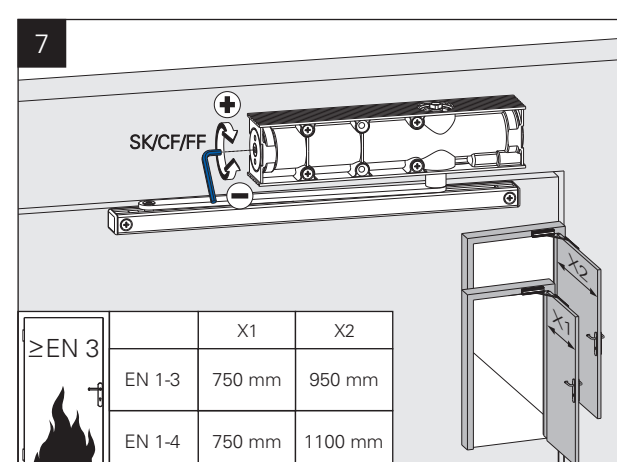
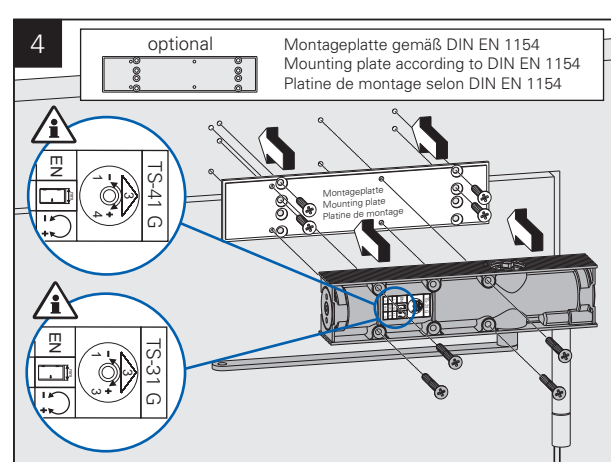
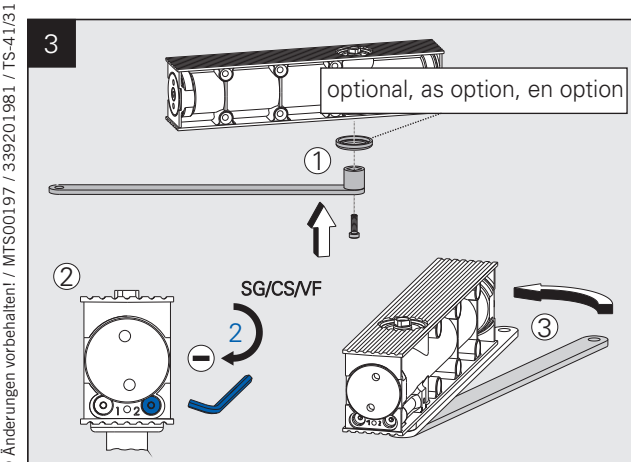
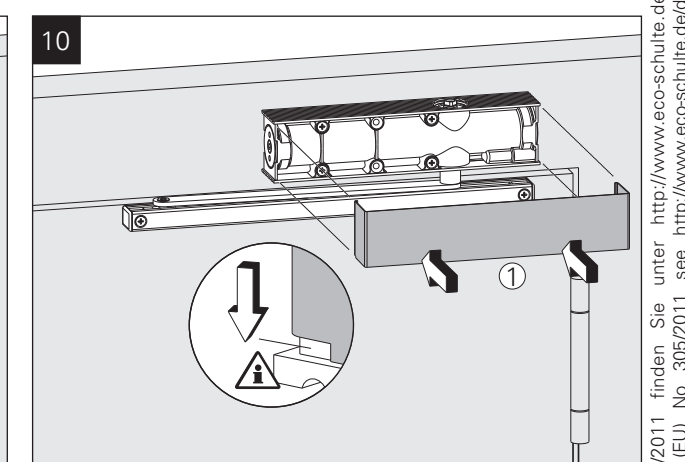
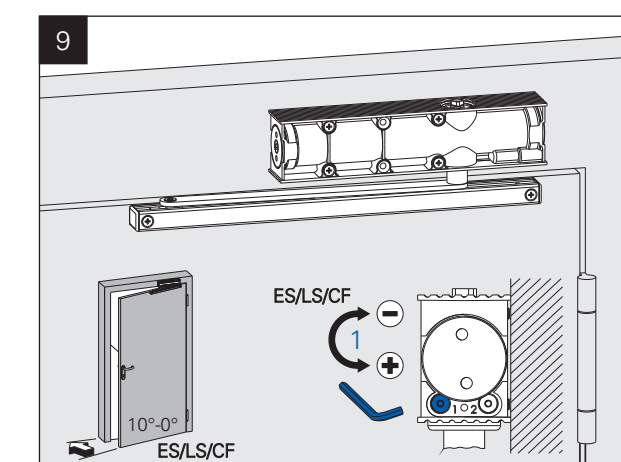
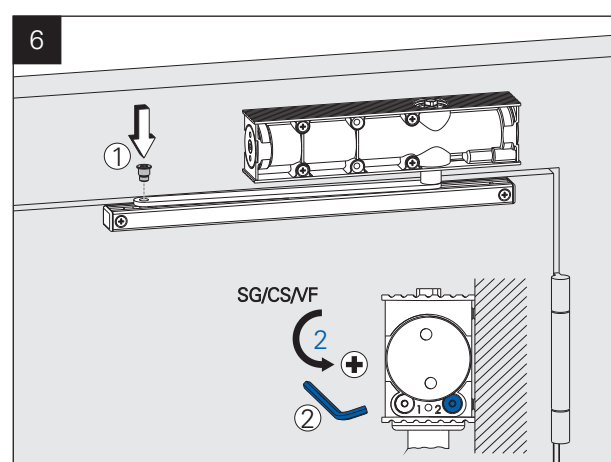
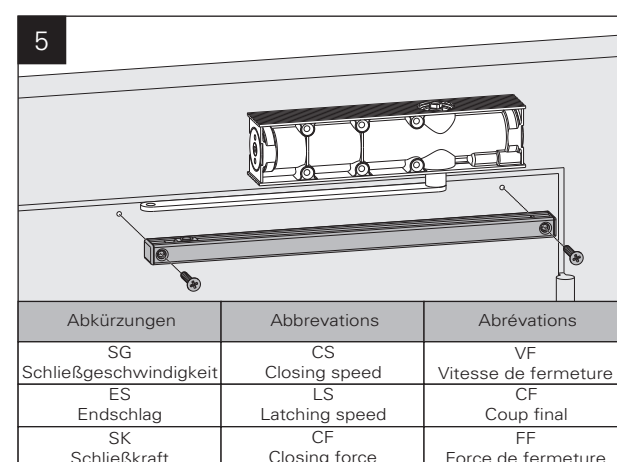
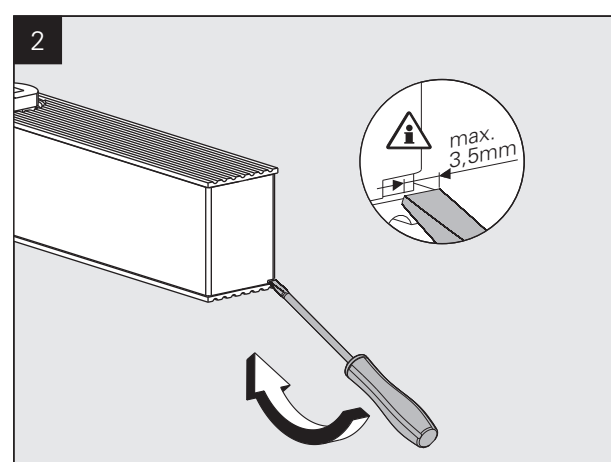
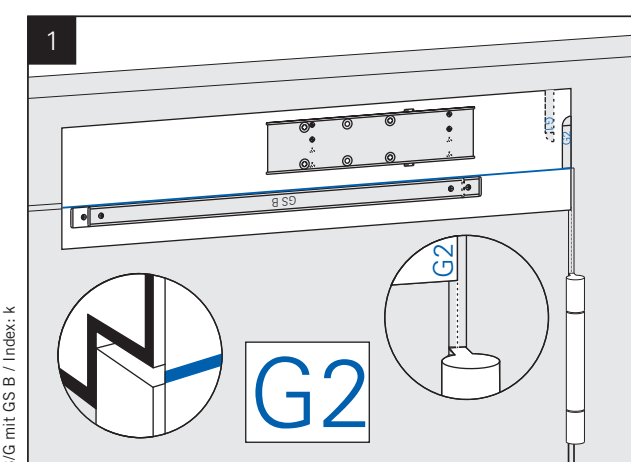
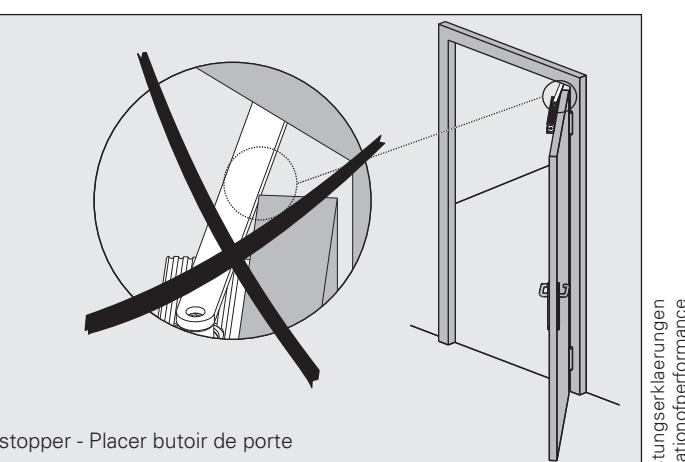
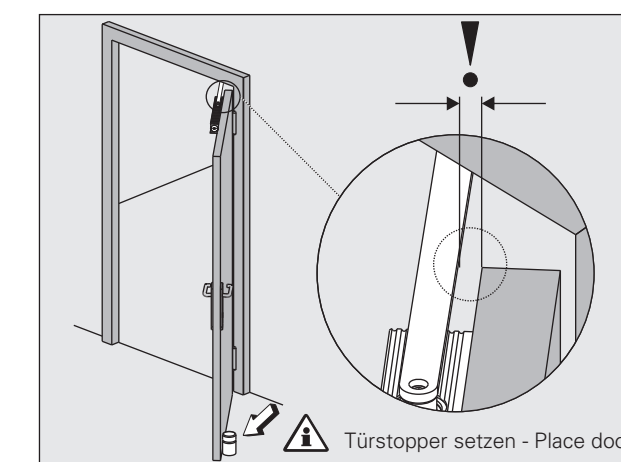
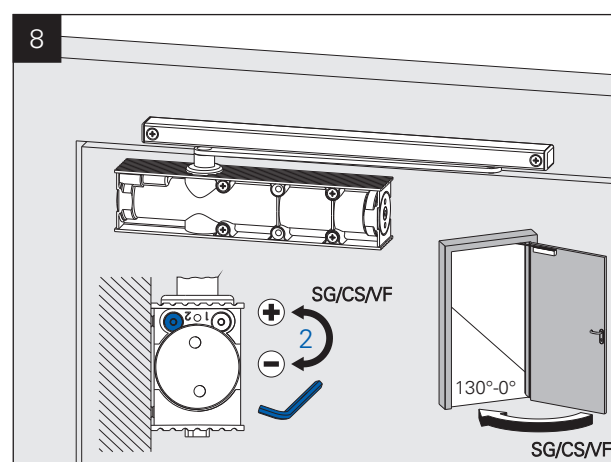
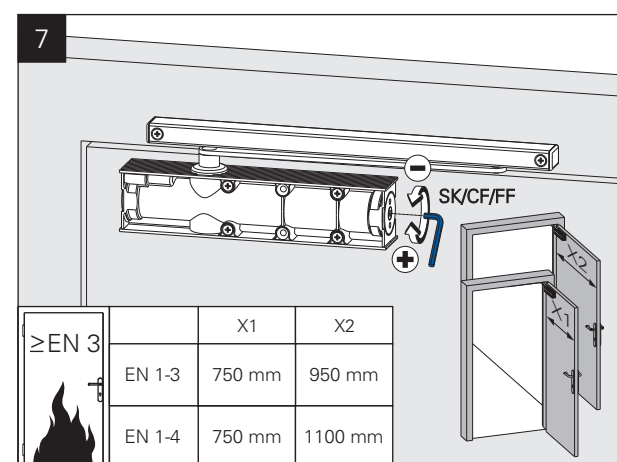
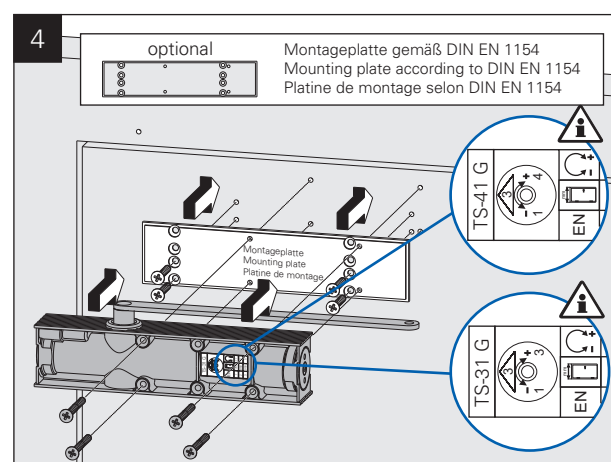
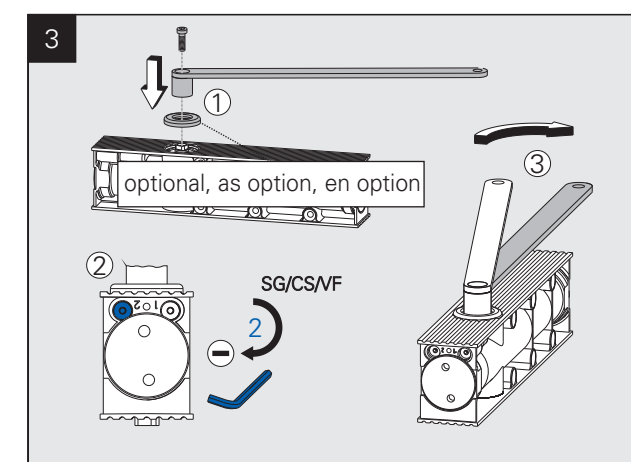
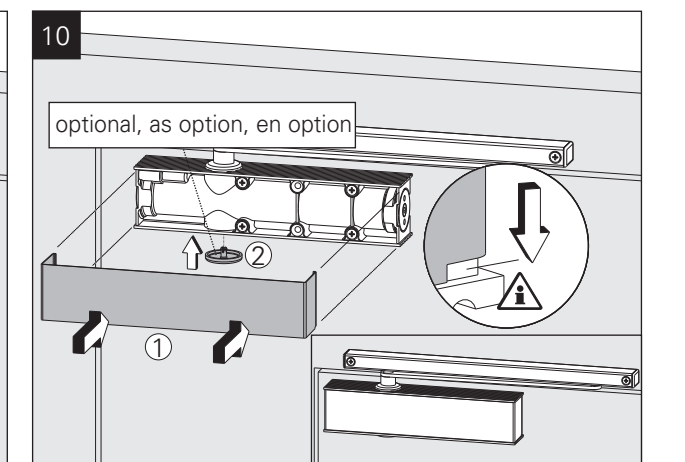
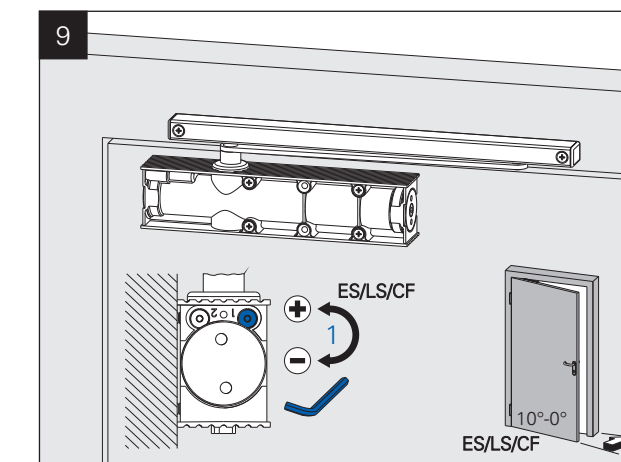
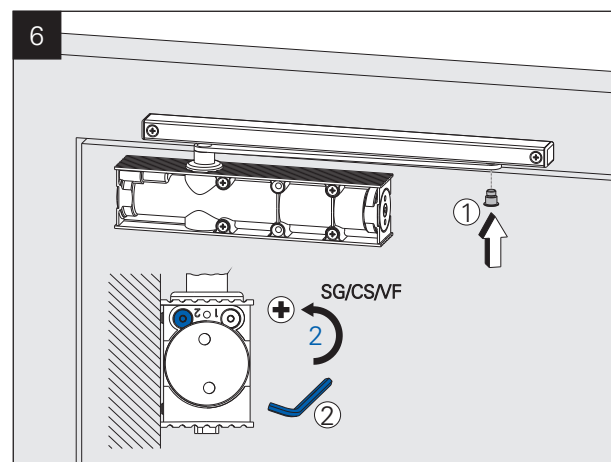
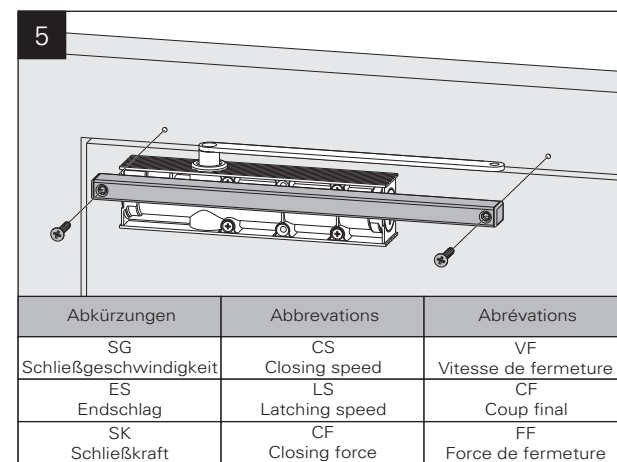
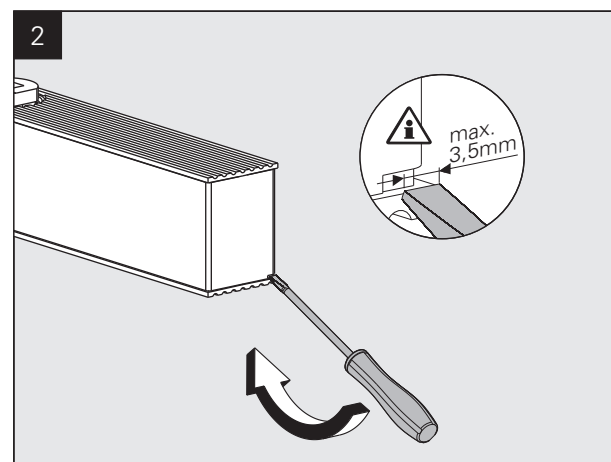
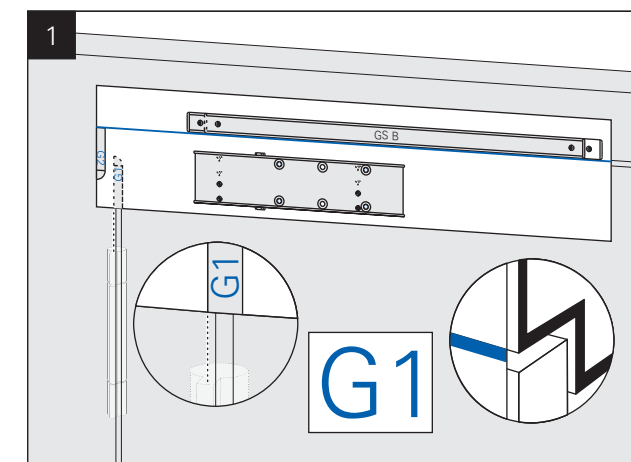

Papiersablonen können sich durch Luftfeuchtigkeit verändern. Verbindlich sind daher nur die Maßangaben.
Paper templates might distort due to air moisture. Only the indicated measurements are therefore obligatory.
Les gabarits en papier peuvent avoir des dimensions modifiées par l'humidité de l'air. Seules les côtes mentionnées doivent être respectées.

GS B

Ø 2,5
Ø 4,2 (M5)

428,5 (G4)
428,5 (G3)

120 \pm 1 (G4)
120 \pm 1 (G3)

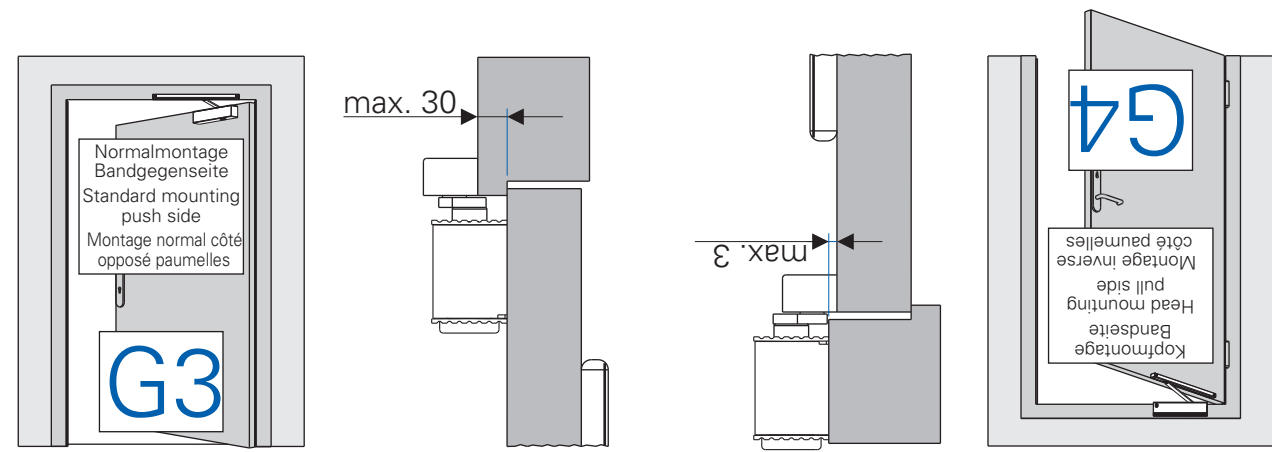

DIN links / left / gauche

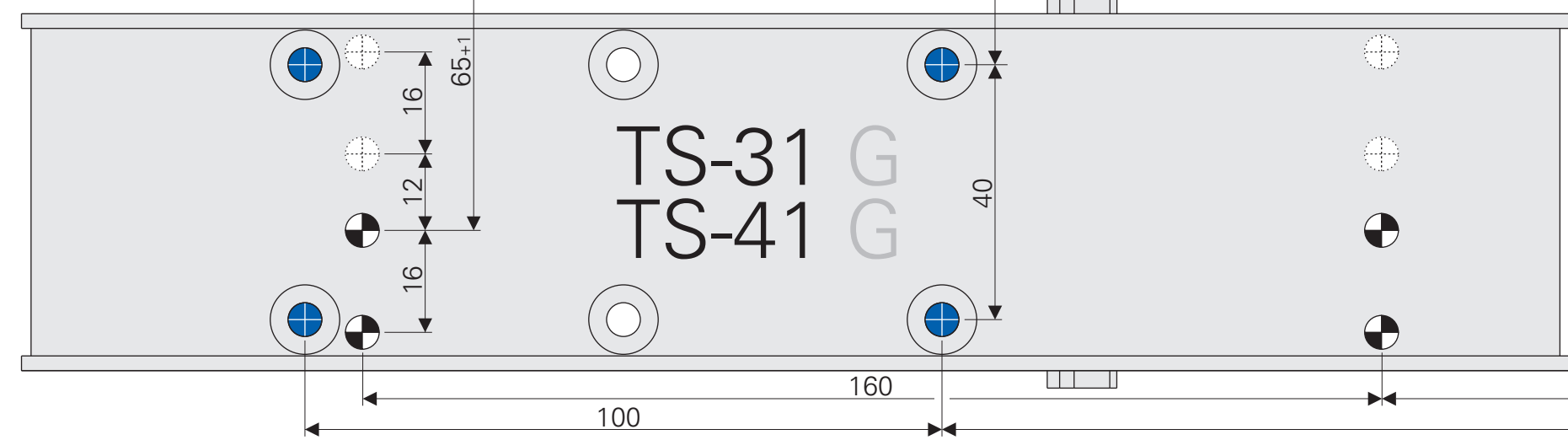

Bohrungen für Montageplatte
Drillings for mounting plate
Alésage pour platine de montage

Bohrungen für Direktmontage
Drillings for direct mounting
Alésage pour montage direct

TS-31 EN 1-3
TS-41 EN 1-4

CE	ECO Schulte GmbH & Co. KG Islerlohner Landstraße 89 D-58706 Menden	10
	0432 - CPD - 0031	EN 1154:1996+A1:2002
		4 8 1-3 1 1 3
		4 8 1-4 1 1 3

Türschließergröße Door closer size Force de ferme porte	Max. Türbreite Max. door width Largeur de porte max.	Umdrehungen Rotations Rotations
■1	750 mm	-11
■2	850 mm	-6
■3	950 mm	0

Türschließergröße Door closer size Force de ferme porte	Max. Türbreite Max. door width Largeur de porte max.	Umdrehungen Rotations Rotations
■1	750 mm	-7
■2	850 mm	-4
■3	950 mm	0
■4	1100 mm	+5

Für die Montage dürfen ausschließlich Originalteile des Herstellers verwendet werden. Die Montagearbeiten müssen gemäß Anleitung von einer qualifizierten Person durchgeführt werden. Bei Nichtbeachtung entfällt jeglicher Garantieanspruch. Diese Anleitung ist vom Monteur nach der Montage an den Betreiber weiterzugeben!

Only original parts have to be used. The assembly has to be made by a qualified person according to the mounting instruction. In case of non-respect the guarantee is invalid. This instruction is to be handed over to the operator by the fitter after assembly!

Impérativement utiliser la notice de montage fournie par le fabricant. La mise en œuvre et le montage doivent être exécutés par du personnel qualifié. Le non respect de ces règles annule catégoriquement tout droit de garantie. Cette instruction est à remettre par le poseur à l'exploitant après montage.

